

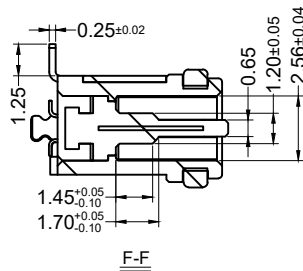

REV	DESCRIPTION	DATE	APPROVED
A	新版发行	2020.11.06	HHM

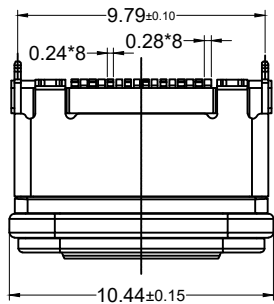

CAP DIMENSIONS

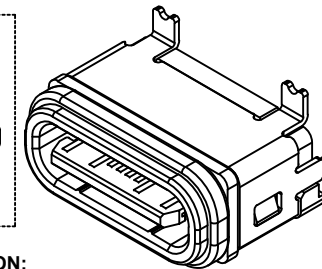
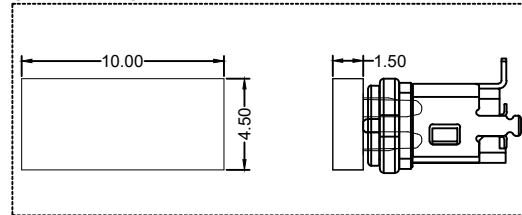

SPECIFICATION:

- CURRENT RATING: 5.0 A
- VOLTAGE RATING: 5.0 V
- VBUS & GND PINS AND OTHER PINS: 40mΩ/PIN MAX  
SHIELD: 50mΩ/MAX  
LLCR MAX. CHANGE OF ALL PINS: 10mΩ
- INSULATION RESISTANCE: 100MΩ MIN
- DIELECTRIC WITHSTAND VOLTAGE, AC 100V FOR 1MINUTE
- INSERTION FORCE: 0.5-2.0kgf
- UNMATING FORCE: 0.8-2.0kgf
- DURABILITY: 10000 CYCLES
- OPERATING TEMPERATURE: -25°C~+85°C
- THE PEAK TEMPERATURE ON THE BOARD SHALL BE MAINTAINED FOR 10 SECONDS AT 260°C
- WATERPROOF: IP67

A

A

B

B

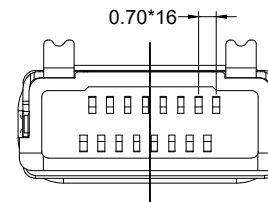
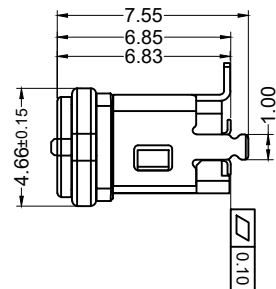
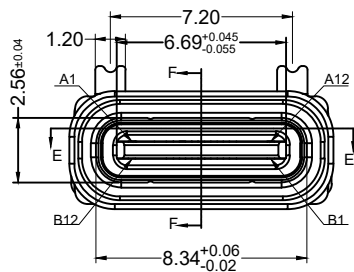

C

C

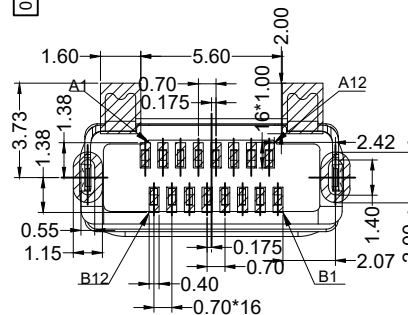
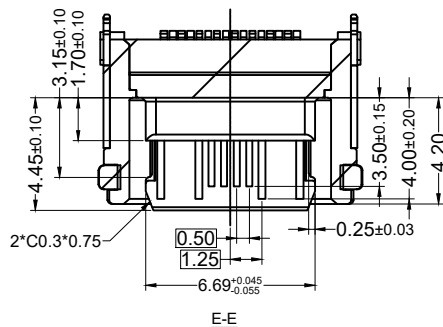

A1	A2	A3	A4	A5	A6	A7	A8	A9	A10	A11	A12
GND			VBUS	CC1	D+	D-	SBU1	VBUS			GND
B12	B11	B10	B9	B8	B7	B6	B5	B4	B3	B2	B1
GND			VBUS	SBU2	D-	D+	CC2	VBUS			GND

RECOMMENDED PCB LAYOUT  
TOLERANCE: ±0.05



CUSTOMER DRAWING			铭创科技（东莞）有限公司 Mingchuang Technology (Dongguan) Co., Ltd.		
UNITS mm	SCALE 1:1	SHEET 1 OF 2	TITLE 防水TYPE C母座16PIN 立贴SMT L=6.8 带贴板脚		
PROJECTION: 	DRAW: DAP	CHECK: HWT	MAT'L SEE TABLE	FINISH SEE TABLE	
GENERAL TOLERANCE 0. ±0.35 0.0 ±0.25 0.00 ±0.15 0.° ±4° 0.0° ±3°	APPD: HHM	DWG. NO. A04W1602A	PART NO. _____	SIZE A4	

D

D

1	SHELL	STAINLESS STEEL	SUS304 Ni PLATED
1	SHEATH	HIGH TEMPERATURE PLASTIC	PA46 BLACK UL 94 V-0
2	MID PLATE	STAINLESS STEEL	SUS304 NO PLATED
3	HOUSING	HIGH TEMPERATURE PLASTIC	PA9T BLACK UL 94 V-0
4	CONTACT	COPPER ALLOY(C7025)	Au PLATING ON CONTACT AREA
5	WATERPROOF RING	SILICA GEL	RED
NO.	PARTS	MATERIAL	REMARKS

1

2

3

4

5

6



REV	DESCRIPTION	DATE	APPROVED
A	新版发行	2020.11.06	HHM

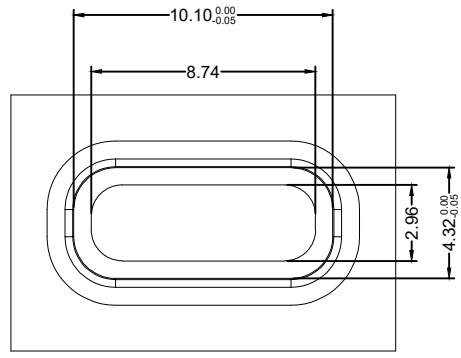
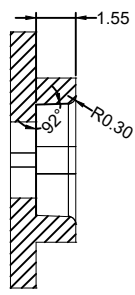
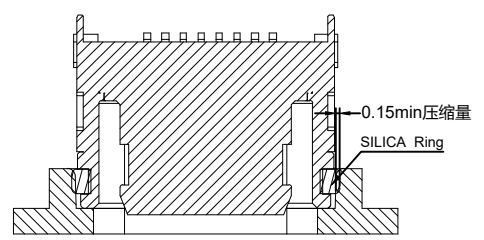
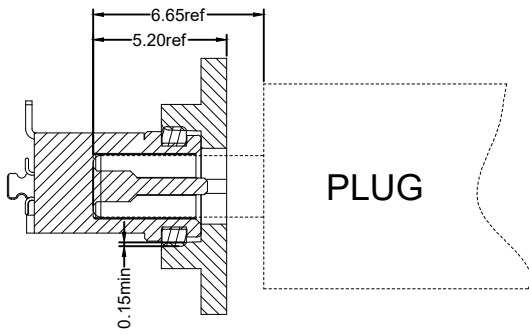
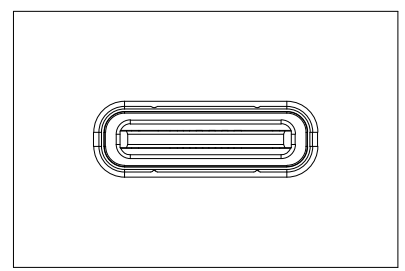
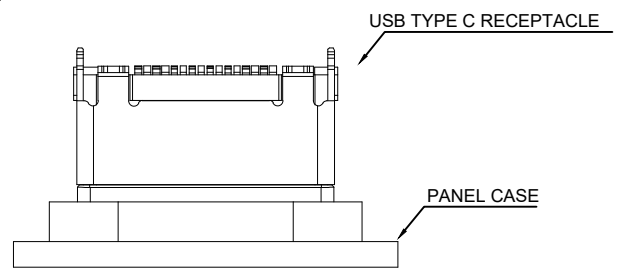

PANEL CASE DIMENSIONS

RELATIVE POSITON FOR APPLICATION



CUSTOMER DRAWING			铭创科技（东莞）有限公司 Mingchuang Technology (Dongguan) Co., Ltd.		
UNITS mm	SCALE 1:1	SHEET 1 OF 2	TITLE 防水TYPE C母座16PIN 立贴SMT L=6.8 带贴板脚		
PROJECTION: 		DRAW: DAP	MAT'L SEE TABLE	FINISH SEE TABLE	
GENERAL TOLERANCE 0. ±0.35 0.0 ±0.25 0.00 ±0.15 0.° ±4° 0.0° ±3°		CHECK: HWT	DWG. NO. A04W1602A	PART NO. _____	SIZE A4
APPD: HHM					



REV	DESCRIPTION	DATE	APPROVED
A	新版发行	2020.11.06	HHM

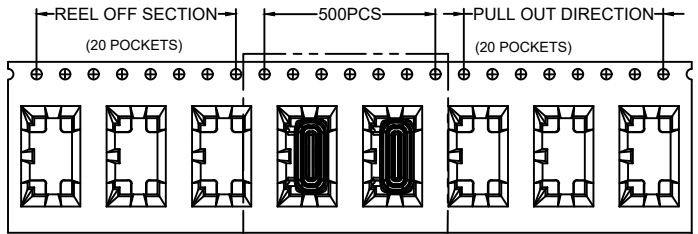

	REEL	CARTON
CONNECTOR (PCS)	500	3500

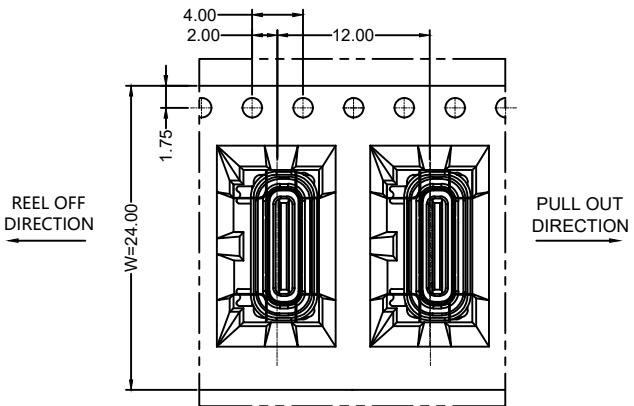
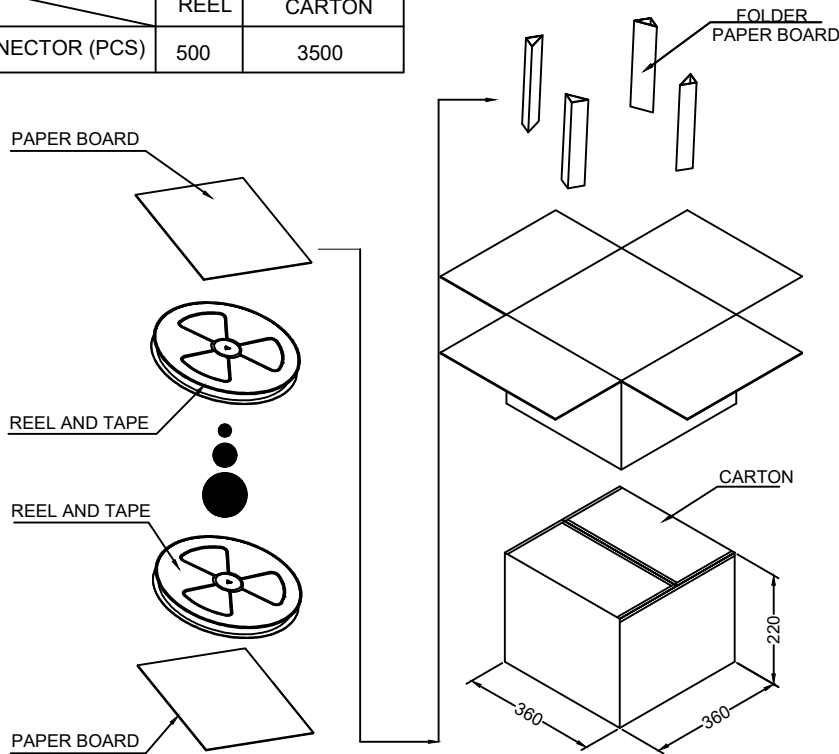
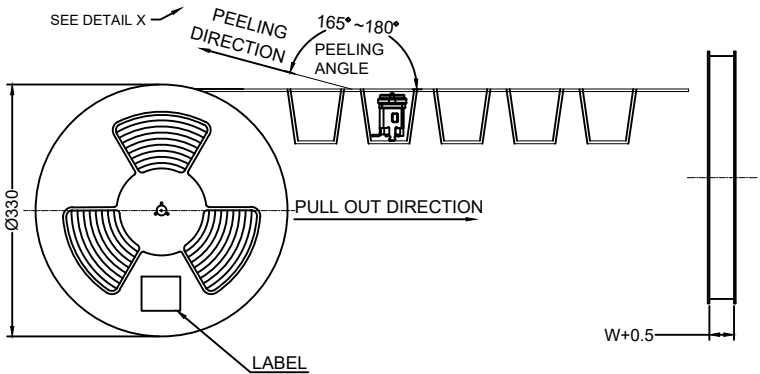

CUSTOMER DRAWING			铭创科技(东莞)有限公司 Mingchuang Technology (Dongguan) Co., Ltd.		
UNITS mm	SCALE 1:1	SHEET 1 OF 2	TITLE 防水TYPE C母座16PIN 立贴SMT L=6.8 带贴板脚		
PROJECTION: 		DRAW: DAP	MAT'L SEE TABLE	FINISH SEE TABLE	
GENERAL TOLERANCE 0. ±0.35 0.0 ±0.25 0.00 ±0.15 0.° ±4° 0.0° ±3°		CHECK: HWT	DWG. NO. A04W1602A	PART NO. _____	SIZE A4
		APPD: HHM			