

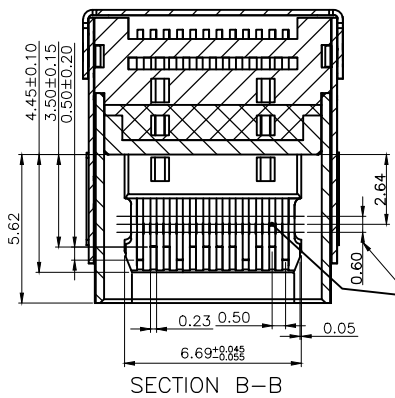

REV	DESCRIPTION	DATE	APPROVED
A	新板发行	2023.05.05	HHM

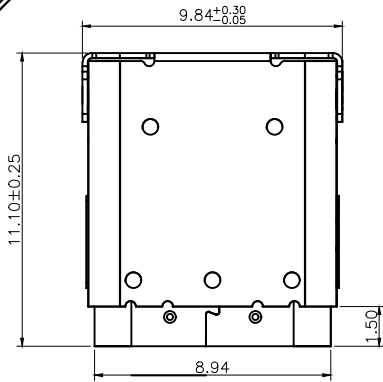

膜厚测试区域

NOTES:  
 1.MATERIAL:  
 MOLDING: LCP UL94 V-0  
 CONTACT: COPPER ALLOY.  
 PLATED GOLD ON CONTACT AREA,  
 G/F GOLD ON SOLDER AREA,  
 50u" NICKEL PLATING OVER ALL.  
 OUTER SHELL: SUS304,T=0.20±0.03mm  
 50u" NICKEL PLATING OVER ALL.  
 G/F FOOT BRUSHING GOLD  
 INNER SHELL: SUS304,T=0.30±0.03mm  
 50u" NICKEL PLATING OVER ALL.  
 LATCH: SUS301,T=0.15±0.03mm  
 2.MECHANICAL:  
 INSERTION: 5~20N.  
 EXTRACTION: 8~20N.  
 DURABILITY: 10000 CYCLES  
 3.ELECTRICAL:  
 CURRENT: 5A MAX FOR VBUS;  
 1.25A FOR GND,0.25A FOR OTHER OTHER.  
 VOLTAGE: 20VDC MAX  
 WITHSTANDING VOLTAGE: 100V AC.  
 CONTACT RESISTANCE: 40mΩ MAX.  
 INSULATION RESISTANCE: 100MΩ MIN.  
 4.ENVIRONMENTAL  
 TEMPERATURE RANGE -40°C ~ +85°C

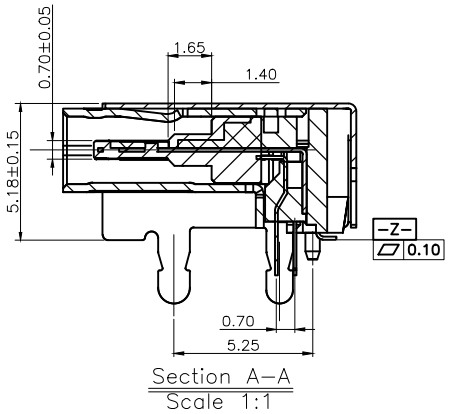
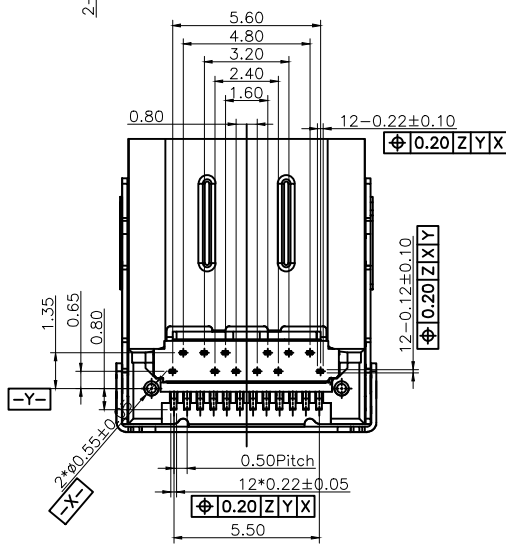
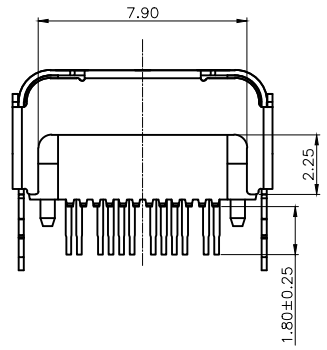
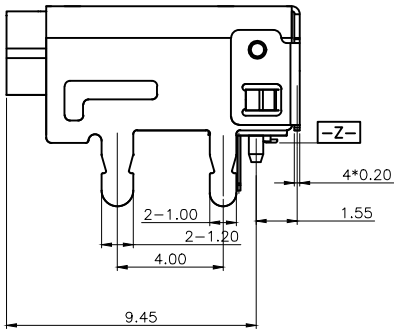
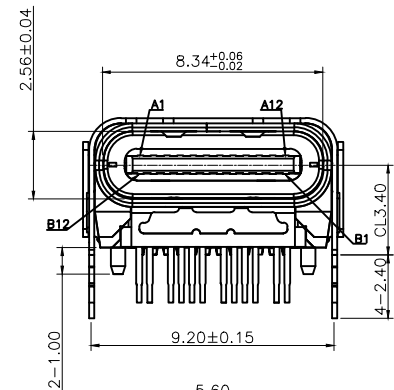

CUSTOMER DRAWING			铭创科技(东莞)有限公司 Mingchuang Technology (Dongguan) Co., Ltd		
UNITS mm	SCALE 1:1	SHEET 1 OF 4	TITLE TYPE C母座24PIN 板上四脚插板DIP+SMT L=11.1 CH=3.4 双壳 三模 有柱 无弹		
PROJECTION: 	DRAW: DAP	CHECK: HWT	MAT'L SEE TABLE	FINISH SEE TABLE	
GENERAL TOLERANCE .000 ±0.02 .00 ±0.10 .0 ±0.20 .0 ±2° .00 ±1°	APPD: HHM	DWG. NO. C392408A	PART NO. _____	SIZE A4	



REV	DESCRIPTION	DATE	APPROVED
A	新板发行	2023.05.05	HHM

USB TYPE-C FULL-FEATURED RECEPTACLE INTERFACE PIN ASSIGNMENTS

PIN	Signal Name	Description	PIN	Signal Name	Description
A1	GND	Ground return	B12	GND	Ground return
A2	SSTXp1	Positive half of first SuperSpeed TX differential pair	B11	SSRXp1	Positive half of first SuperSpeed RX differential pair
A3	SSTXn1	Negative half of first SuperSpeed TX differential pair	B10	SSRXn1	Negative half of first SuperSpeed RX differential pair
A4	VBUS	Bus Power	B9	VBUS	Bus Power
A5	CC1	Configuration Channel	B8	SBU2	Sideband Use (SBU)
A6	Dp1	Positive half of the USB 2.0 differential pair-Position 1	B7	Dn2	Negative half of the USB 2.0 differential pair-Position 2
A7	Dn1	Negative half of the USB 2.0 differential pair-Position 1	B6	Dp2	Positive half of the USB 2.0 differential pair-Position 2
A8	SBU1	Sideband Use (SBU)	B5	CC2	Configuration Channel
A9	VBUS	Bus Power	B4	VBUS	Bus Power
A10	SSRXn2	Negative half of second SuperSpeed RX differential pair	B3	SSTXn2	Negative half of second SuperSpeed TX differential pair
A11	SSRXp2	Positive half of second SuperSpeed RX differential pair	B2	SSTXp2	Positive half of second SuperSpeed TX differential pair
A12	GND	Ground return	B1	GND	Ground return

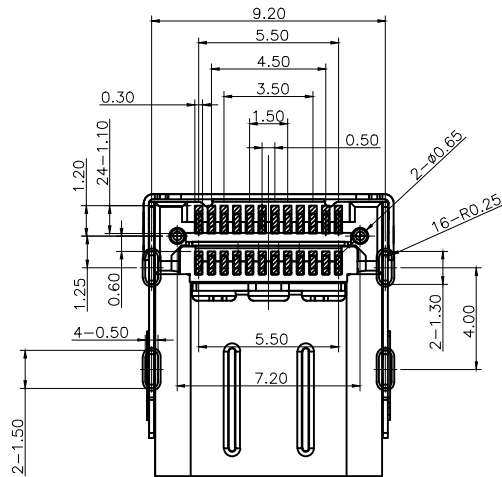

RECOMMENDED PCB LAYOUT (COMPONENT SIDE)

PCB THICKNESS: 1.60±0.05  
DEFAULT TOLERANCE: ±0.05

8	UPPER CONTACT	12	COPPER ALLOY	PLATED GOLD ON CONTACT AREA, 3U" GOLD ON SOLDER AREA, 50U" NICKEL PLATING OVER ALL.
7	LOWER CONTACT	12	C18400	
6	LOWER IM	1	THERMOPLASTIC LCP UL94V-0	COLOR: BLACK
5	UPPER IM	1	THERMOPLASTIC LCP UL94V-0	COLOR: BLACK
4	OVERMOLD	1	THERMOPLASTIC LCP UL94V-0	COLOR: BLACK
3	LATCH PLATE	1	STAINLESS STEEL SUS301	CLEANLY
2	INNER SHELL	1	STAINLESS STEEL SUS304	50u" NICKEL PLATING OVER ALL.
1	OUTER SHELL	1	STAINLESS STEEL SUS304	50u" NICKEL PLATING OVER ALL, AU AT SOLDER TAIL
NO.	DESCRIPTION	QTY	MATERIAL	SPECIFICATION

CUSTOMER DRAWING		
UNITS mm	SCALE 1:1	SHEET 2 OF 4
PROJECTION: 	DRAW: DAP	
GENERAL TOLERANCE .000 ±0.02 .00 ±0.10 .0 ±0.20 .0 ±2° .00 ±1°	CHECK: HWT	
	APPD: HHM	

铭创科技 (东莞) 有限公司 Mingchuang Technology (Dongguan) Co., Ltd		
TITLE TYPE C母座24PIN 板上四脚插板SMT+SMT L=11.1 CH=3.4 双壳 三模 有柱 无弹		
MAT'L SEE TABLE	FINISH SEE TABLE	
DWG. NO. C392409A	PART NO. _____	SIZE A4

1

2

3

4

5

6



REV	DESCRIPTION	DATE	APPROVED
A	新板发行	2023.05.05	HHM

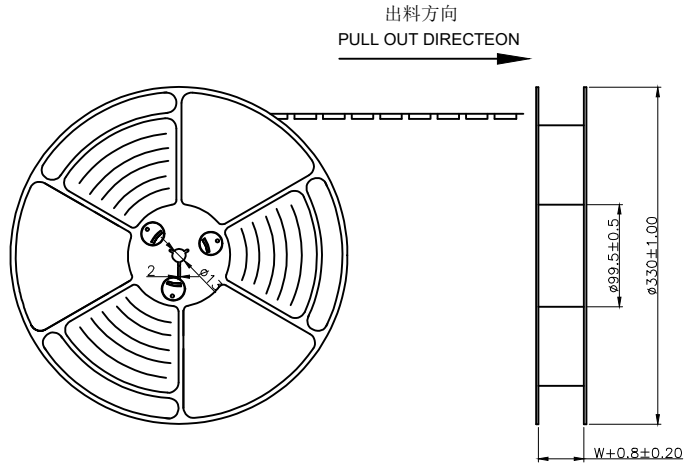

NOTES

- 1. 帶子引導長度  
LEAD TAPE LENGTH  
出料方向  
PULL OUT DIRECTION

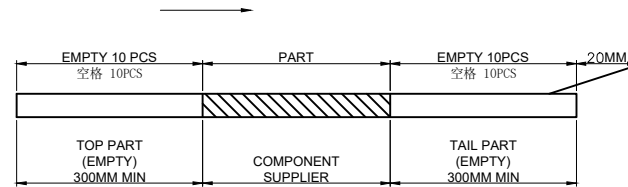

- 2. 出貨運輸過程中一定要注意:  
THIS REQUIREMENT SHOULD BE APPLIED AT SHIPMENT:  
卷帶在運輸過程中不能散開  
PEELING OFF SHOULD NOT BE ALLOWED DURING TRANSPORTATION

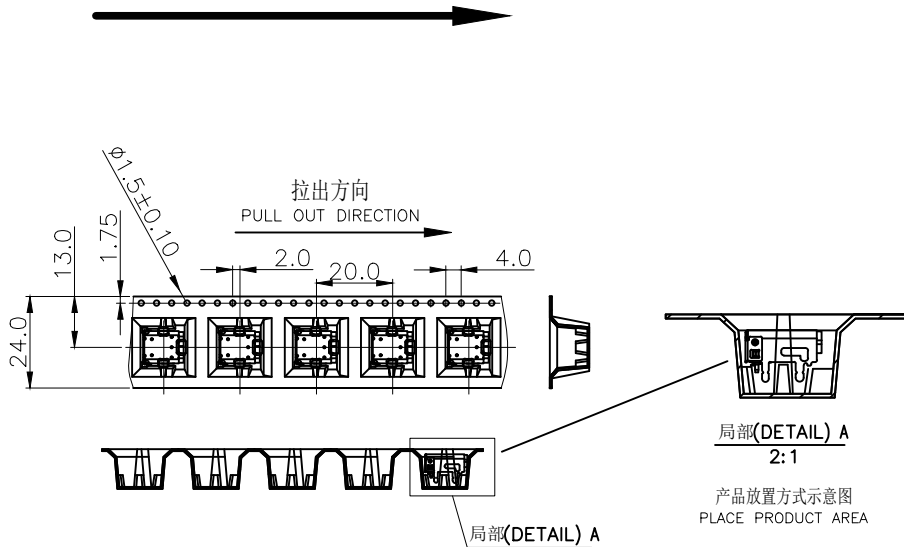

CUSTOMER DRAWING			铭创科技(东莞)有限公司 Mingchuang Technology (Dongguan) Co., Ltd		
UNITS mm	SCALE 1:1	SHEET 3 OF 4	TITLE TYPE C母座24PIN 板上四脚插板SMT+SMT L=11.1 CH=3.4 双壳 三模 有柱 无弹		
PROJECTION: 	DRAW: DAP	CHECK: HWT	MAT'L SEE TABLE	FINISH SEE TABLE	
GENERAL TOLERANCE .000 ±0.02 .00 ±0.10 .0 ±0.20 .0 ±2° .00 ±1°	APPD: HHM	DWG. NO. C392409A	PART NO. _____	SIZE A4	



REV	DESCRIPTION	DATE	APPROVED
A	新板发行	2023.05.05	HHM

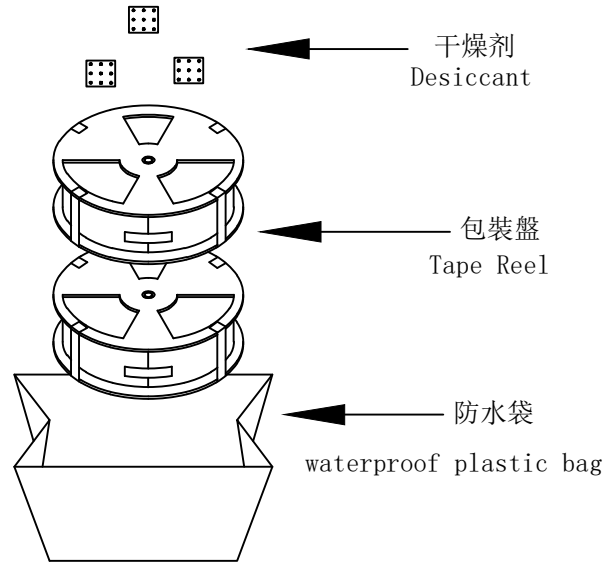

Label pasting location (facing the back of the circular hole on the roll)  
 标签粘贴处 (朝卷带圆孔反面)  
 Location of label sticking (label)

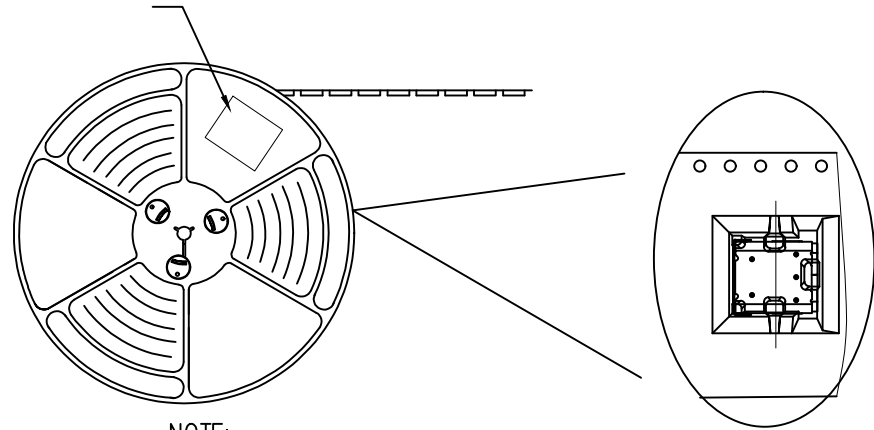

NOTE:

1. 每卷包装数量及每箱装箱数量如左下表格。  
Packing q'ty of each reel & carton as below table shown.
2. 以上带覆盖下载带经包装机自粘包装  
The above tape covers the download tape by self-adhesive packaging machine.
3. 将装满产品的卷盘放入纸箱并以胶带封口  
Put reels in the carton and use adhesive tape to seal up.

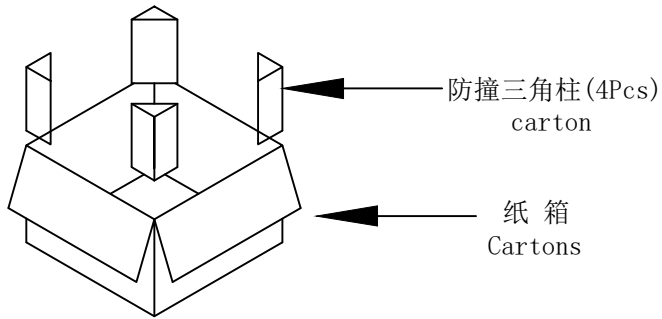

CUSTOMER DRAWING			铭创科技 (东莞) 有限公司 Mingchuang Technology (Dongguan) Co., Ltd		
UNITS mm	SCALE 1:1	SHEET 4 OF 4	TITLE TYPE C母座24PIN 板上四脚插板SMT+SMT L=11.1 CH=3.4 双壳 三模 有柱 无弹		
PROJECTION: 	DRAW: DAP	CHECK: HWT	MAT'L SEE TABLE	FINISH SEE TABLE	
GENERAL TOLERANCE .000 ±0.02 .00 ±0.10 .0 ±0.20 .0 ±2° .00 ±1°	APPD: HHM	DWG. NO. C392409A	PART NO. _____	SIZE A4	

产品料号 (PRODUCT No.)	包装数量 (PACKING CAPACITY)			重量 WEIGHT (Kg)		
	PCS/REEL	REELS/CARTON	PCS/CARTON	N.W./PCS	N.W./BOX	G.W./BOX
	400	10	4000	0.782		